

Total No. of Questions—8]

[Total No. of Printed Pages—4

Seat No.	
-------------	--

**[4956]-107**

**F.E. (Common) EXAMINATION, 2016**

**ENGINEERING GRAPHICS-I**

**(2012 PATTERN)**

**Time : Two Hours**

**Maximum Marks : 50**

- N.B. :—** (i) Answer Q. No. 1 or Q. No. 2, Q. No. 3 or Q. No. 4, Q. No. 5 or Q. No. 6, Q. No. 7 or Q. No. 8.
- (ii) Figures to the right side indicate full marks.
- (iii) Assume suitable data if necessary.
- (iv) Retain construction lines.
- (v) Marks are reserved for dimensioning and good presentation.

1. The end A of line AB is 20 mm above HP while its end B is 10 mm in front of VP. Its plan and elevation makes an angle of  $40^\circ$  and  $45^\circ$  with XY respectively. Draw the projection of line, if the distance between end projectors of line is 60 mm. Find its true length, inclination with HP and VP. Also, locate its traces. [12]

*Or*

2. A pentagonal plate of 40 mm side is resting on VP on one of its sides such that the corner opposite to it is 25 mm in front of VP. The side in VP makes an angle of  $20^\circ$  with HP. Draw its projections and find its inclination with HP & VP. [12]

P.T.O.

3. A regular hexagonal pyramid, side of base 25 mm and height 60 mm is resting on one of its corner on HP such that slant edge passing through the resting corner is perpendicular to HP and plan of axis is inclined at  $45^\circ$  to VP. Draw its projections when apex is towards the observer. [13]

Or

4. (a) The major and minor diameter of an ellipse is 110 and 90 mm respectively. Draw an ellipse rectangle method. [7]  
 (b) Draw the development of lateral surface of hexagonal prism having side of base 35 mm and height 70 mm. [6]

5. The following Fig No. 1 shows a cast iron bracket. By using first angle projection method draw : [13]

- (1) Front view along arrow X  
 (2) Top view  
 (3) Sectional LHSV along plane A-A  
 Give all the dimensions :

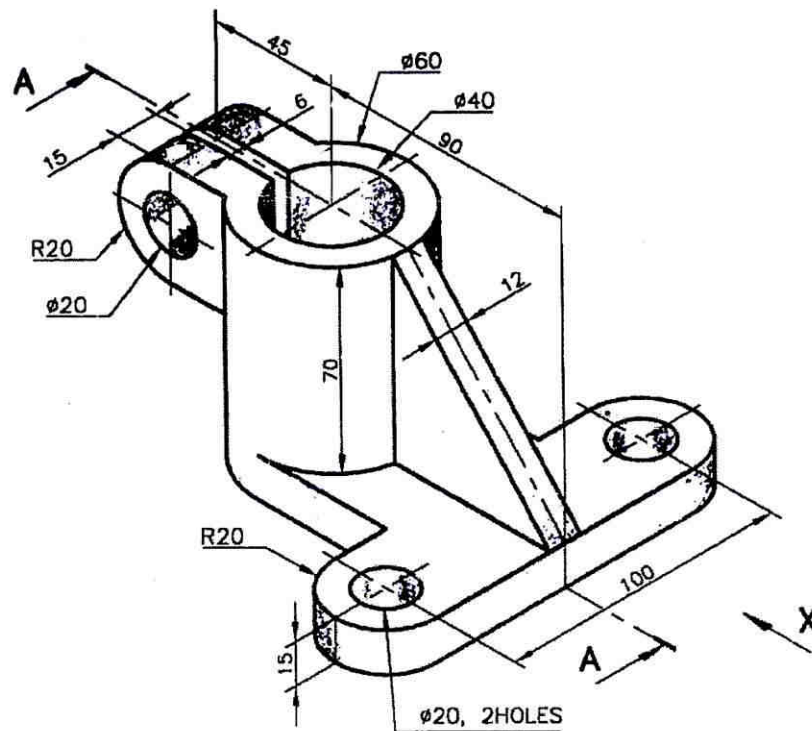

Fig No. 1 C.I. Bracket

Or

6. The following Fig. No. 2 shows a cast iron bracket. By using first angle projection method draw : [13]

- (1) Sectional front view along plane A-A
- (2) Top view
- (3) LSHV

Give all the dimensions.

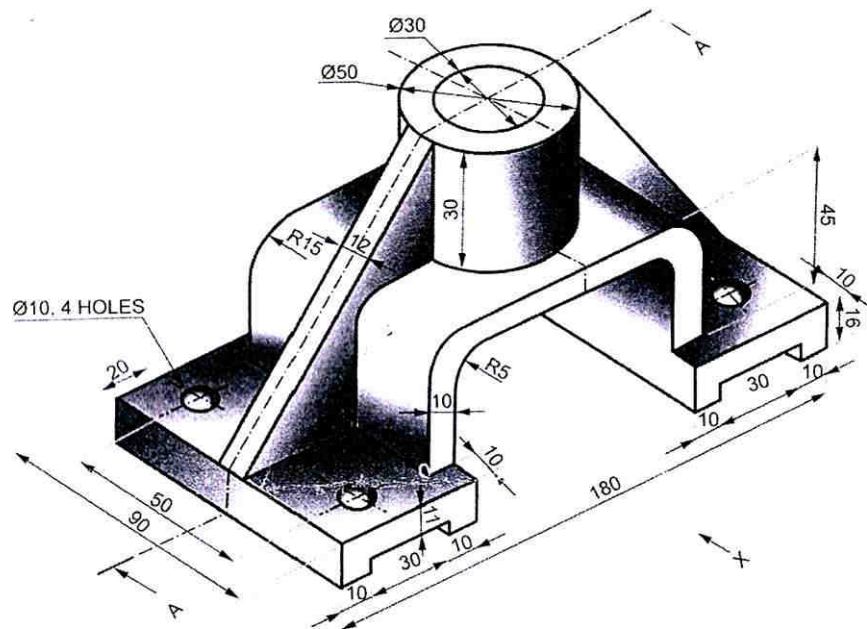

Fig No. 2 C.I. Bracket

7. Fig. No. 3 shows the FV and LHSV of an object. Draw the isometric view using natural scale. [12]

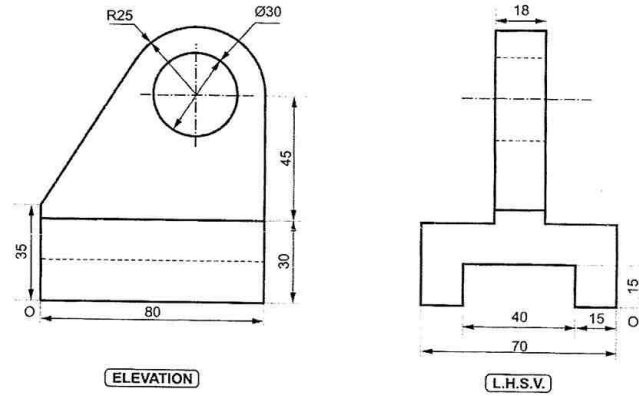

Fig. No. 3  
Or

8. Fig. No. 4 shows the FV and Top view of an object. Draw the isometric view using natural scale. [12]

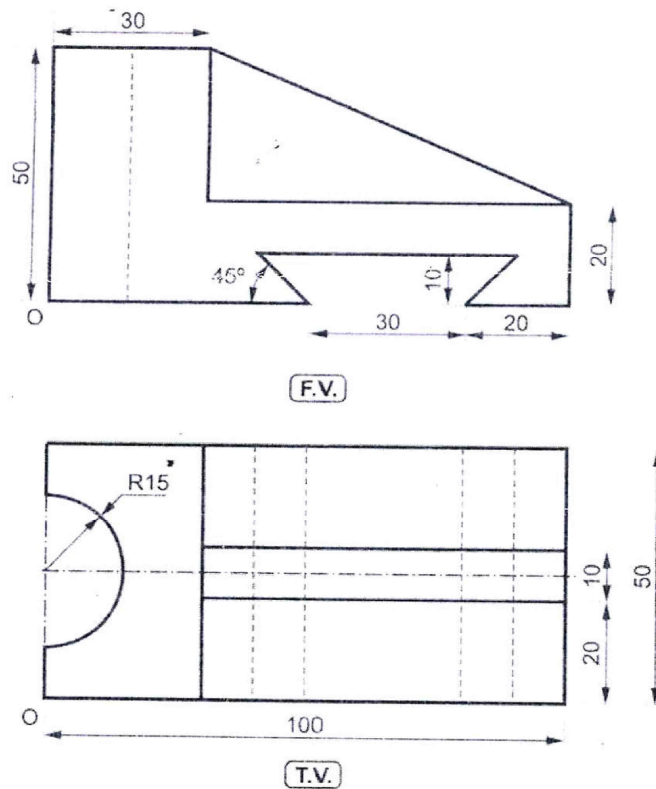

Fig. No. 4